

NEW!

**Delta DP Control System
for thrusters and rudders**



**PRODUCT
RANGE**

ALAMARIN-JET

CONTENT

ALAMARIN-JET NETWORK 4

WATERJETS - AJ Series

AJ 160..... 6

The AJ 160 is the smallest jet in the Alamarin-Jet range, with the majority of applications in luxury pleasure tenders and small commercial vessels. AJ 160 is the only commercially rated waterjet of its size available and as with all Alamarin-Jet products there are no limits on operational profiles.

AJ 180/185..... 8

The AJ 180 and AJ 185 are often used in both leisure and commercial applications, with the majority of applications in luxury pleasure tenders and small commercial vessels, often requiring SOLAS certification. As with all Alamarin-Jet products there are no limits on operational profiles.

AJ 230 10

The AJ 230 is the best selling Alamarin-Jet product of all time, it is now the industry standard for SOLAS Fast Rescue Craft and is renowned world wide for its extremely robust and simple design while maintaining high cavitation limits with high speed vessel performance.

AJ 245..... 12

The AJ 245 is the first jet in the COMBI-FRAME series. The patented Combi-Frame technology allows designers, builders and owners maximum flexibility when locating the position of the propulsion system within the vessel.

AJ 285 14

The AJ 285 is the newest jet in the COMBI-FRAME series. Choosing between 2 different hull installation inserts allows the jet to be installed either in LONG TAIL or SHORT TAIL configuration. Following the success of AJ 245 many customers requested the combi-frame installation method for larger, more powerful vessels. AJ 285 is suitable for engines up to 366 kW/500 HP.

AJ 340 16

The AJ 340 is a lightweight, compact and highly efficient commercial waterjet. Cavitation limits are the highest in class due to Alamarin-Jets leading hydrodynamic design, without reducing top speed capabilities. AJ 340 is suitable for large military and commercial fast craft, as well as pleasure craft applications.

WATERJETS - Omega Series

Omega 37 18

The Omega 37 is the second largest waterjet in Omega Series, with a max input power of 1000 kW/1360 HP

Omega 42..... 20

The Omega 42 is the first model in the Alamarin-Jet OMEGA SERIES, with a max input power of 1500 kW/2040 HP.



CONTROL SYSTEMS

ACTUATOR CONTROL UNIT - ACU 22

The Actuator Control Unit system or ACU system is a modular propulsion control system designed to be adaptable for multiple configurations with simple selection of modular components.

SIGMA CONTROL SYSTEM.....24

Alamarin-Jet Sigma Control System is an electro-hydraulic integrated drive-by-wire control system. It supports installations from single to quadruple waterjets.

DELTA DP CONTROL SYSTEM 26

Delta DP is a modular high-level propulsion control system that integrates vessel's propulsion, steering and navigation systems. It provides three main controlling modes: Manual control, Dynamic Positioning mode and Autopilot mode.

ALAMARIN-JET NETWORK

Alamarin-Jet Oy are world leading manufacturer of waterjet propulsion units and control systems. Suitable for input power up to 1500 kW / 2040 HP, Alamarin-Jet are renowned for an innovative, robust and efficient design philosophy.

Alamarin-Jet have been pushing waterjet innovation particularly in the last 10 years introducing technical features such as the patented Combi-Frame, a jet frame design which allows for multiple installation methods in AJ 245 and AJ 285 as well as the patented Dual Angle Shaft recently introduced in the Omega Series jets which allows 2 different shaft angles without changing jet inclination. Alamarin-Jet see the importance in future technologies within the marine industry and therefore have invested heavily in next generation control and monitoring system, this includes autonomous operations, remote surveillance and remote monitoring. All built on the Sigma control platform.

A RELIABLE AND SKILLED DEALER NETWORK COVERS 50+ COUNTRIES ALL AROUND THE WORLD, PROVIDING RAPID RESPONSE AND DELIVERING SERVICE AND SPARE PARTS WHEN NEEDED THE MOST. ALAMARIN-JET CONSTANTLY WORK ON DEVELOPING THE NETWORK IN ORDER TO MAINTAIN HIGHEST POSSIBLE LEVEL OF SUPPORT.

ALMOST 50 YEARS SUCCESSFUL EXPERIENCE IN DESIGNING, MANUFACTURING, AND SUPPLYING WATERJET PROPULSION SYSTEMS AROUND THE WORLD

FINNISH QUALITY. OVER 90% MADE IN FINLAND, 10% REMAINING EUROPEAN UNION

BROAD RANGE OF JET SIZES SUITABLE FOR INPUT POWER UP TO 1,500 KW

BEST POWER/SIZE/WEIGHT CHARACTERISTICS IN THE MARKET

HIGHLY ACCURATE PERFORMANCE CALCULATIONS USING THE LATEST SOFTWARE COMBINED WITH YEARS OF EXPERIENCE

FASTEST PRODUCTION LEAD TIMES IN THE INDUSTRY

COMPANY DEDICATED TO SERVICE AND SUPPORT

DEALER/SERVICE NETWORK IN 50+ COUNTRIES

DIRECT FACTORY SUPPORT FOR ALL CUSTOMERS

AJ 160

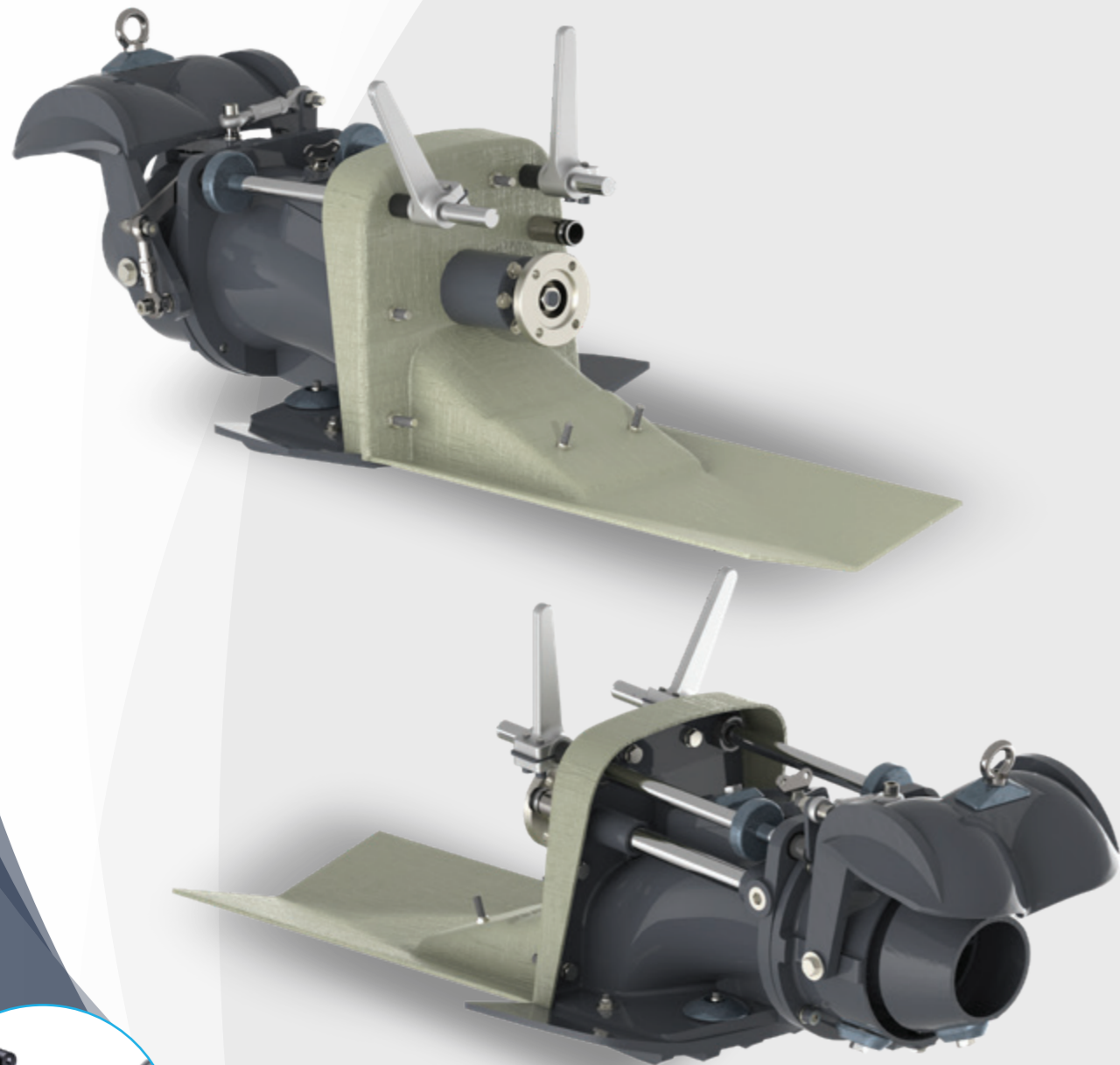

REVERSING DEFLECTOR CONTROL

SPECS



PUMP TYPE
MIXED FLOW,
SINGLE STAGE



IMPELLER SHAFT RPM
MAX. 5000 1/MIN



JET WEIGHT
38 KG
(84 LBS)

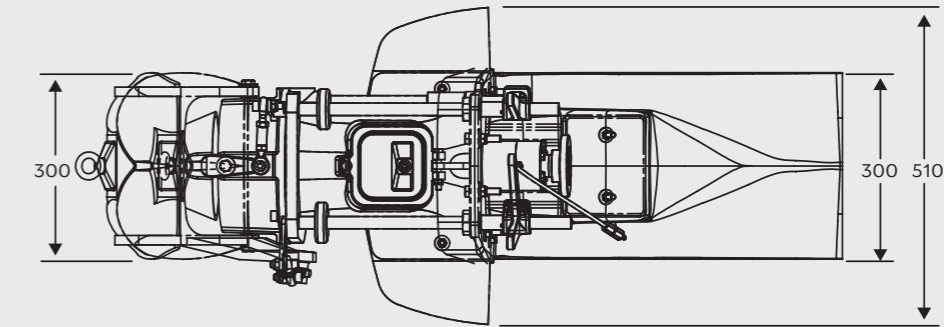
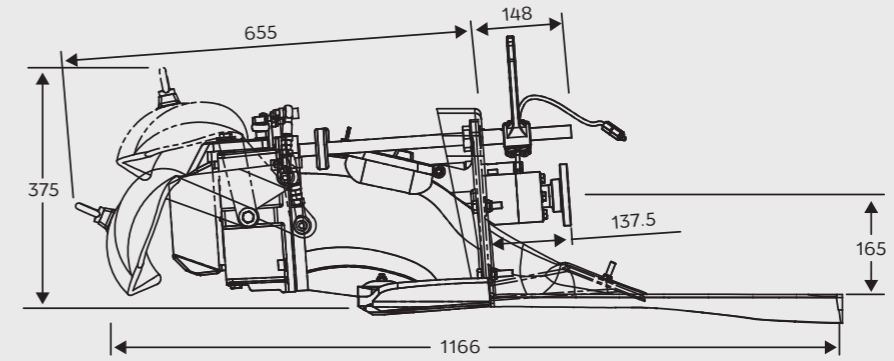

IMPELLER DIAMETER
MAX. 186 MM
(7.3")



MAX INPUT POWER
100 KW
(136 MHP)



JET CONSTRUCTION
ALUMINIUM,
STAINLESS STEEL



REVERSE DEFLECTOR CONTROL
MECHANICAL OR
ELECTRICAL (ACU)

AJ 160 POWER/RPM COVERAGE

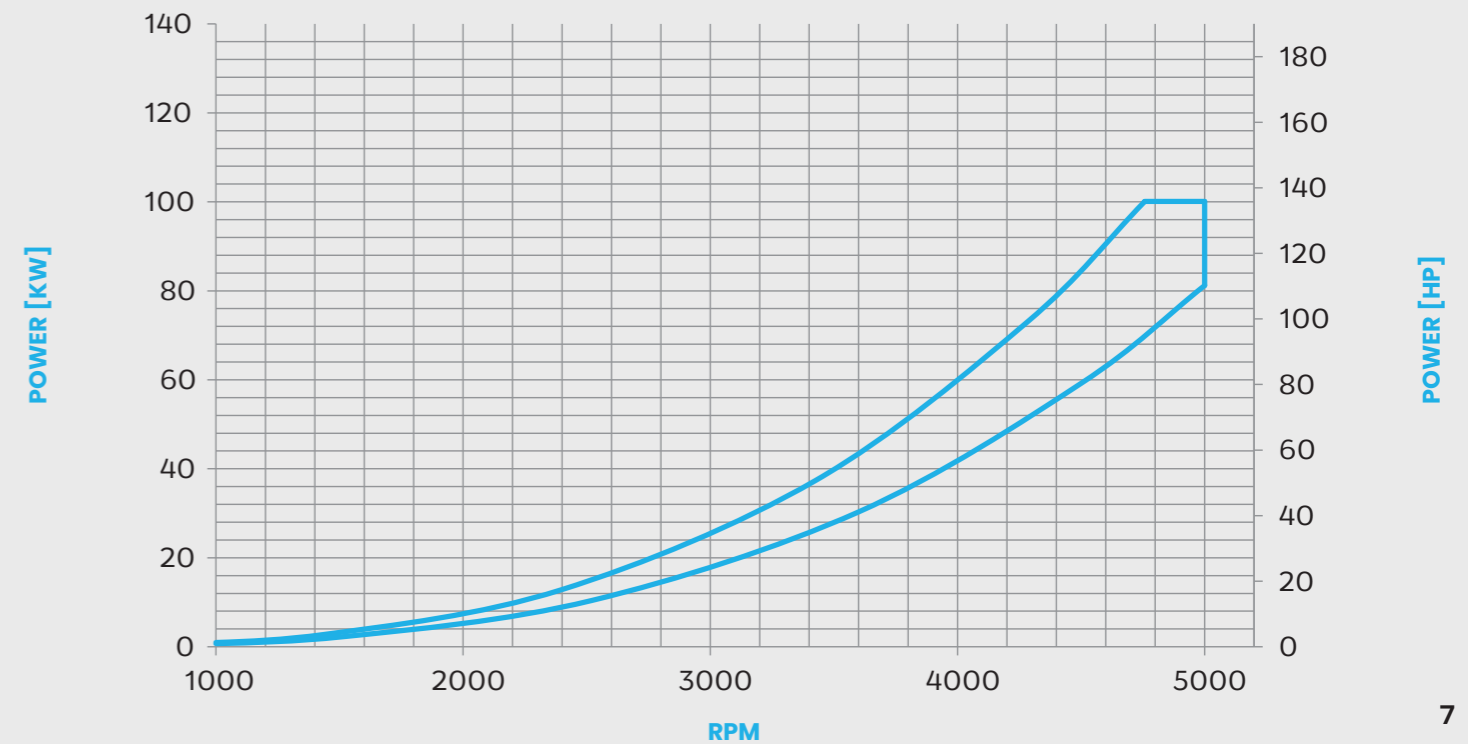

AJ 180/185

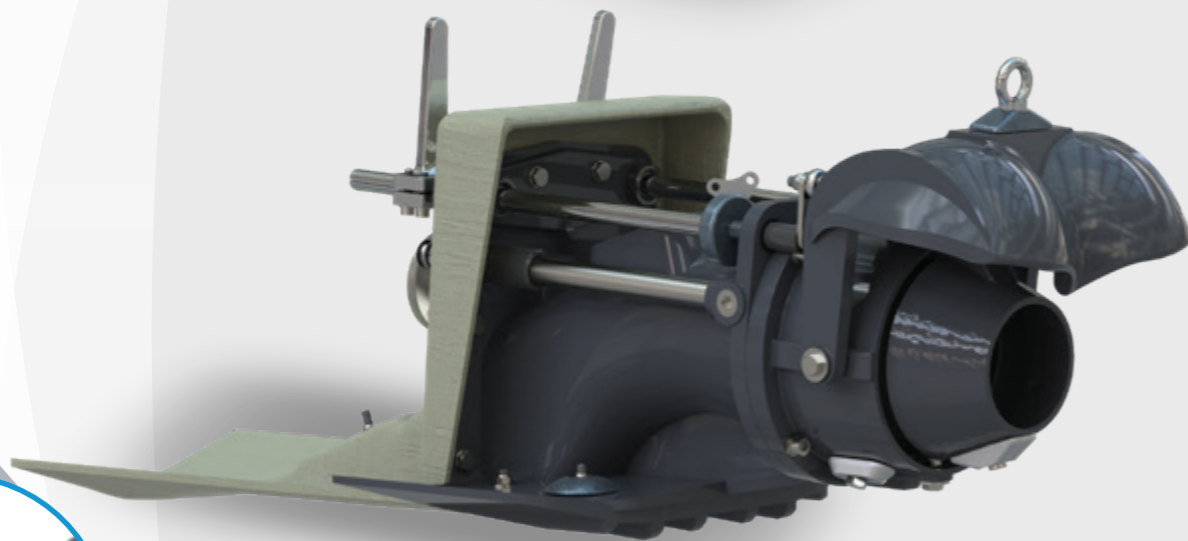
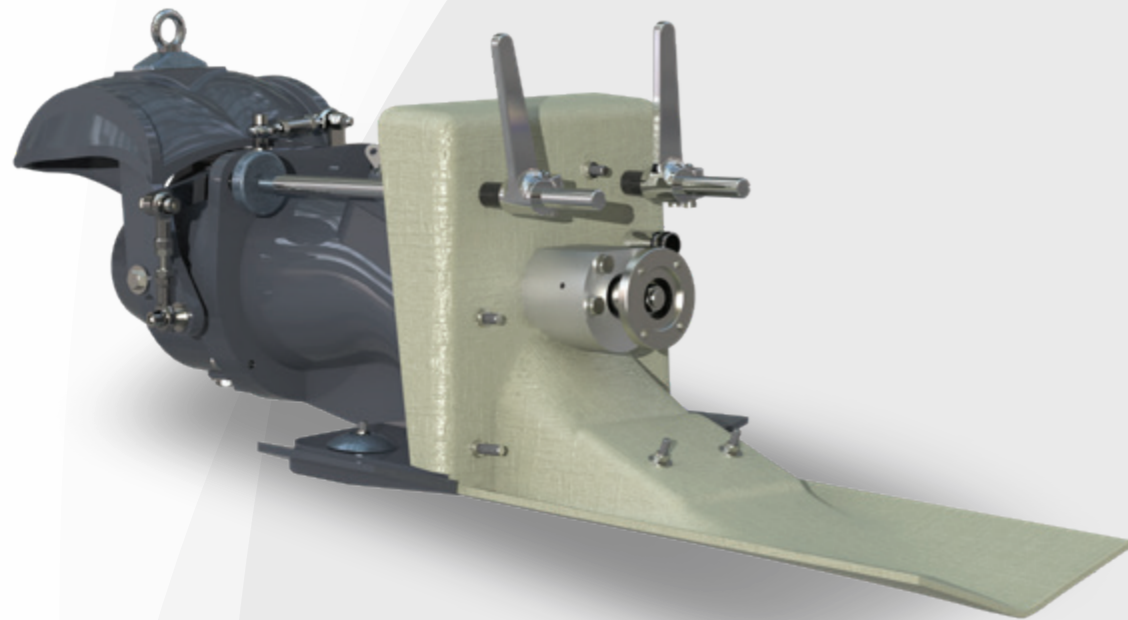

REVERSING DEFLECTOR CONTROL

SPECS



PUMP TYPE
MIXED FLOW,
SINGLE STAGE



IMPELLER SHAFT RPM
MAX. 5000 1/MIN



JET WEIGHT
48 / 50 KG
(106 / 110 LBS)

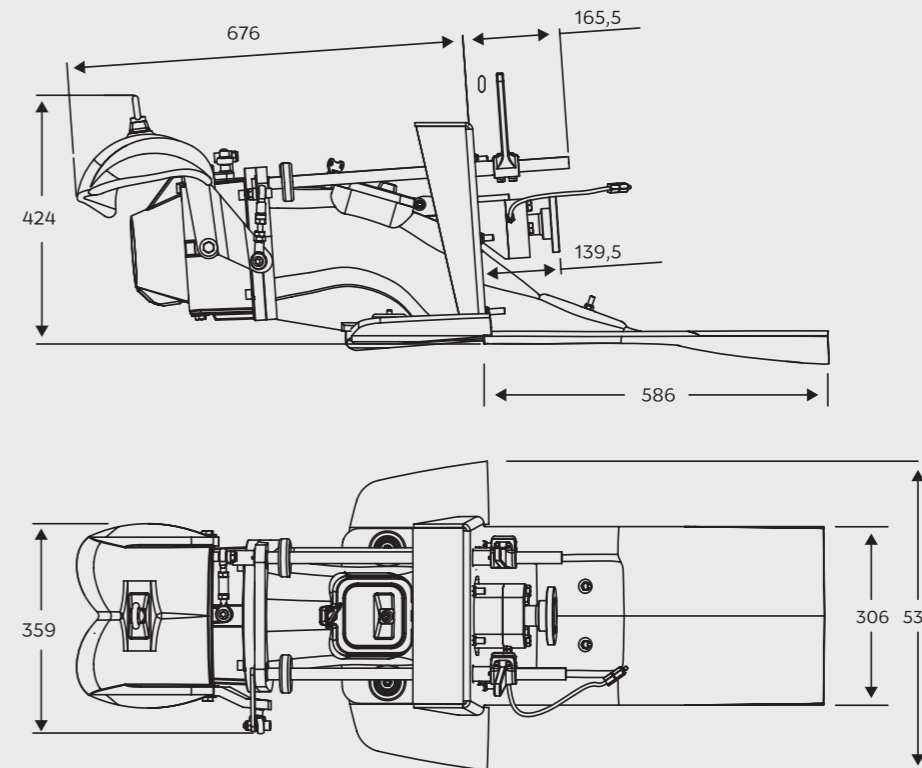

IMPELLER DIAMETER
MAX. 192 / 197 MM
(7.6" / 7.8")



MAX INPUT POWER
120 KW
(163 MHP)



JET CONSTRUCTION
ALUMINIUM,
STAINLESS STEEL



REVERSE DEFLECTOR CONTROL
MECHANICAL OR
ELECTRICAL (ACU)

AJ 180/185 POWER/RPM COVERAGE

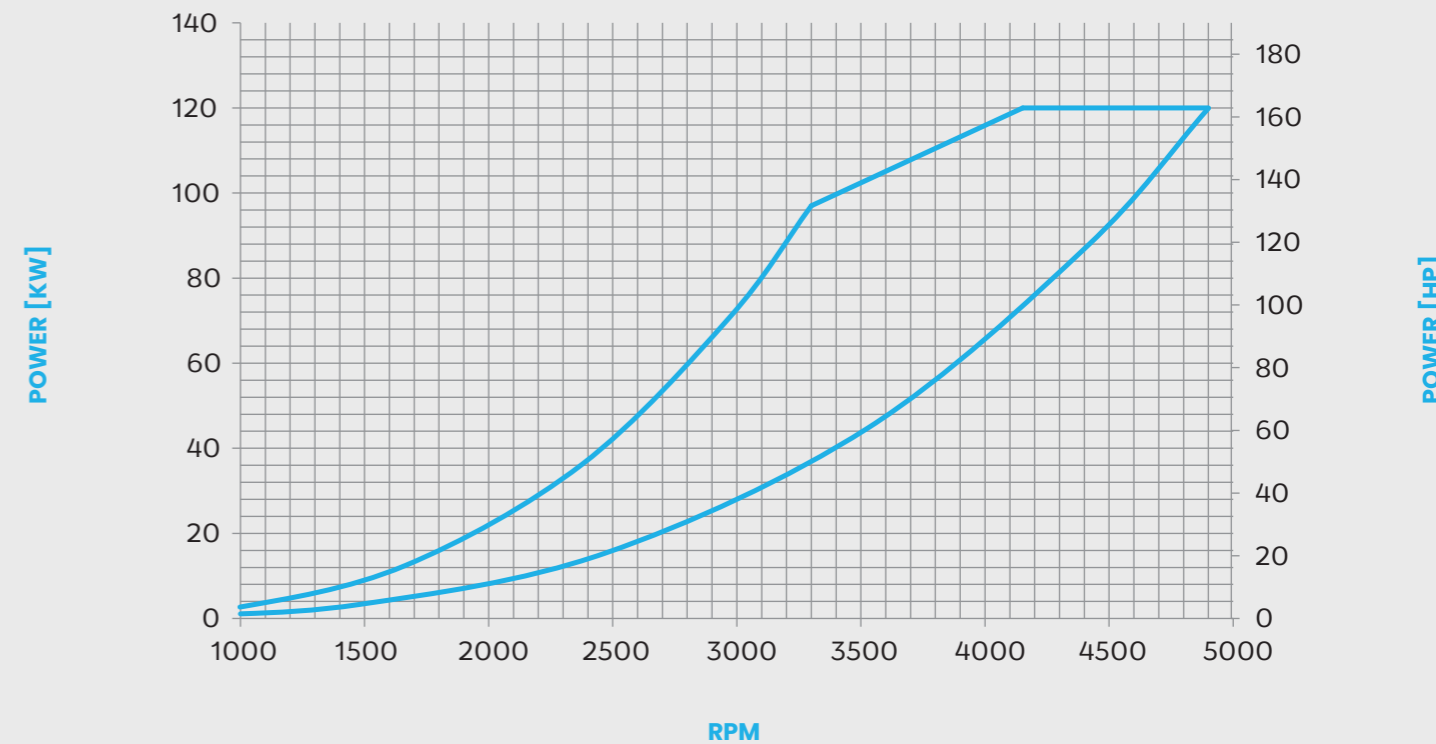

AJ 230

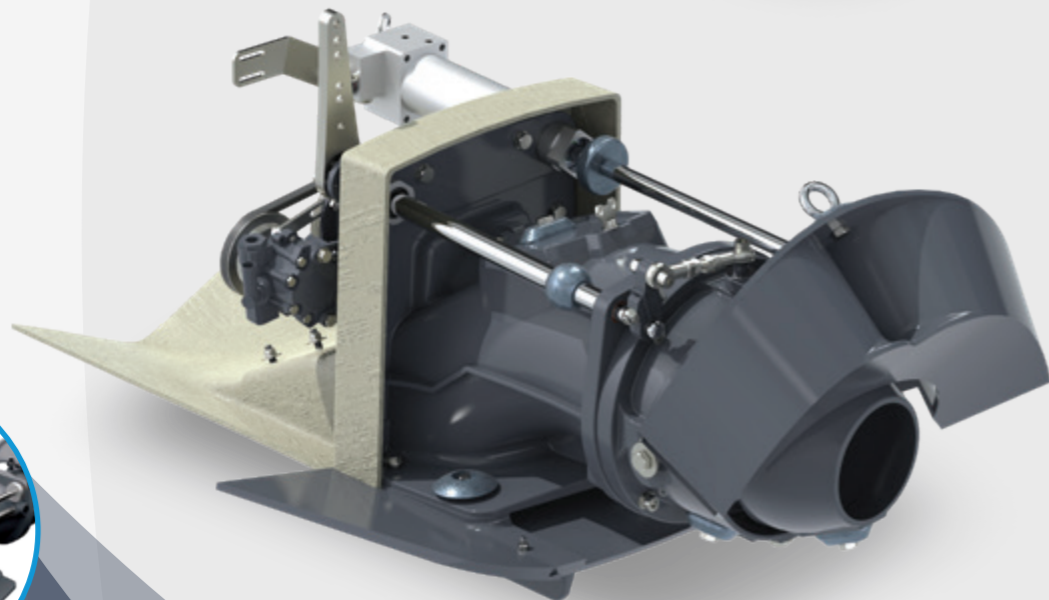
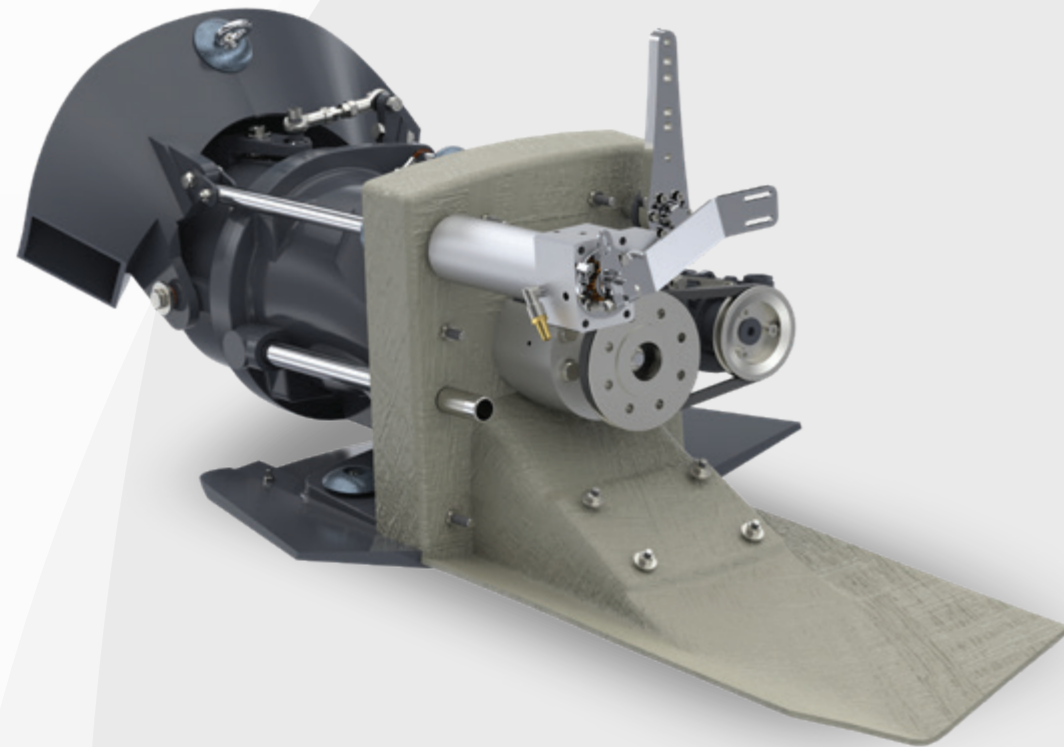

REVERSING
DEFLECTOR
CONTROL

SPECS



PUMP TYPE
MIXED FLOW



IMPELLER SHAFT RPM
MAX. 4600 1/MIN



JET WEIGHT
81 KG / 179 LBS

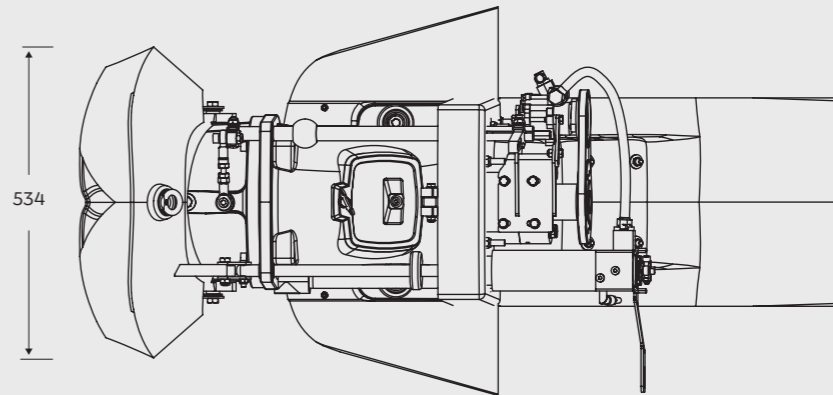
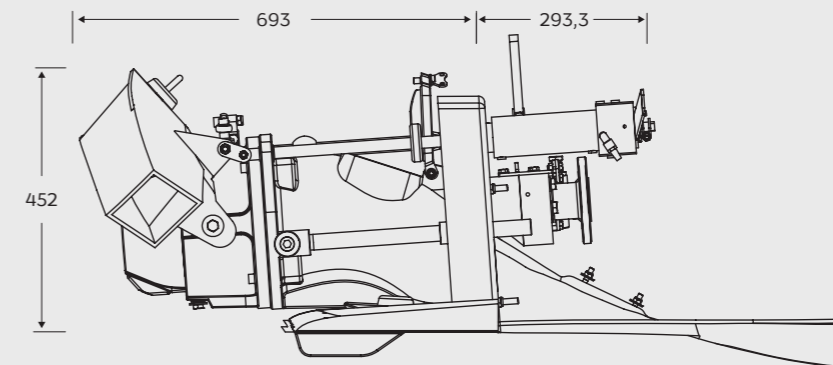

IMPELLER DIAMETER
MAX. 228 MM / 9"



MAX INPUT POWER
190 KW / 260 HP



JET CONSTRUCTION
ALUMINIUM,
STAINLESS STEEL



REVERSE DEFLECTOR CONTROL
HYDRAULIC

AJ 230 POWER/RPM COVERAGE

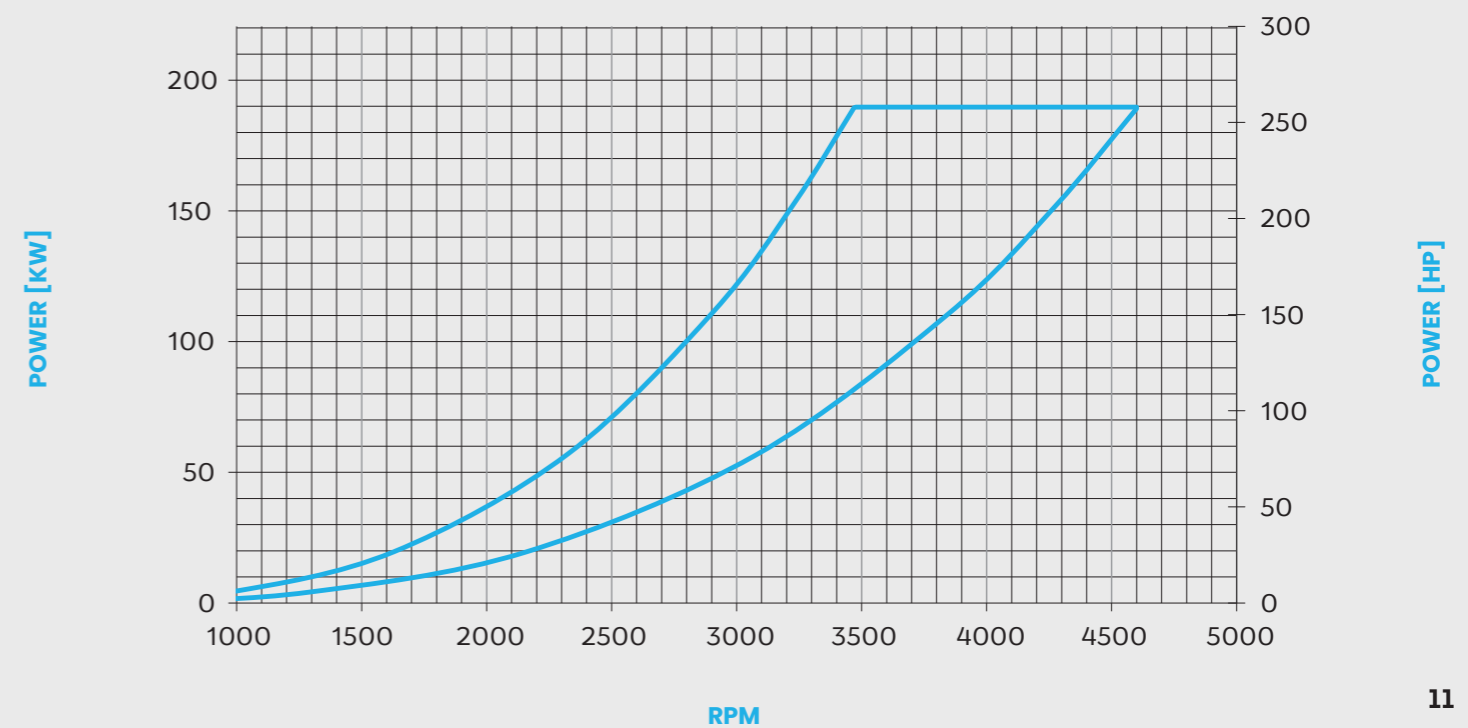

AJ 245

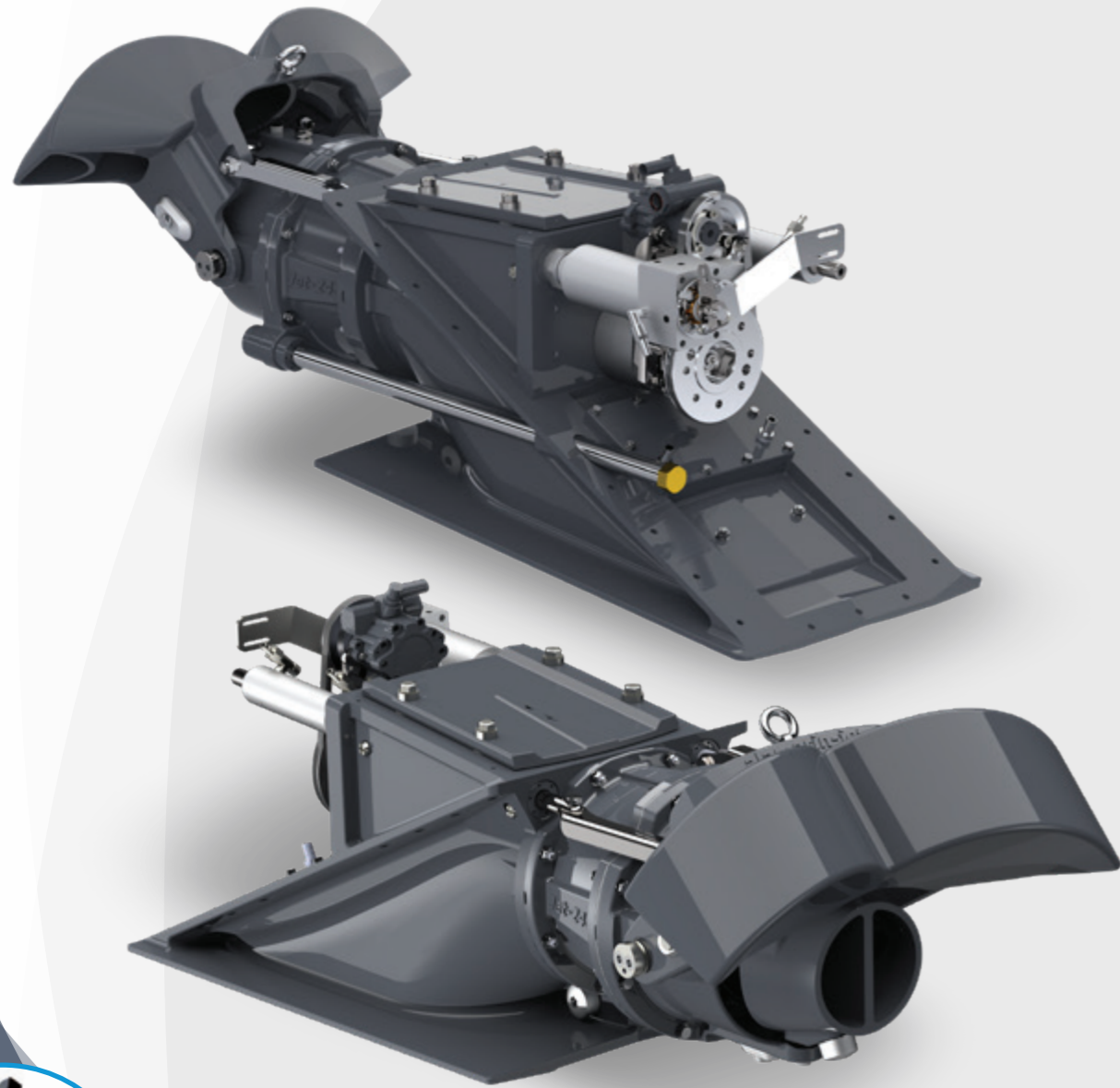

TWO INSTALLATION OPTIONS

PATENTED COMBI-FRAME TECHNOLOGY

Integrated oil cooler and steering cylinder

SPECS



PUMP TYPE
MIXED FLOW,
SINGLE STAGE



IMPELLER SHAFT RPM
MAX. 4600 1/MIN



JET WEIGHT
105 KG
(231 LBS)

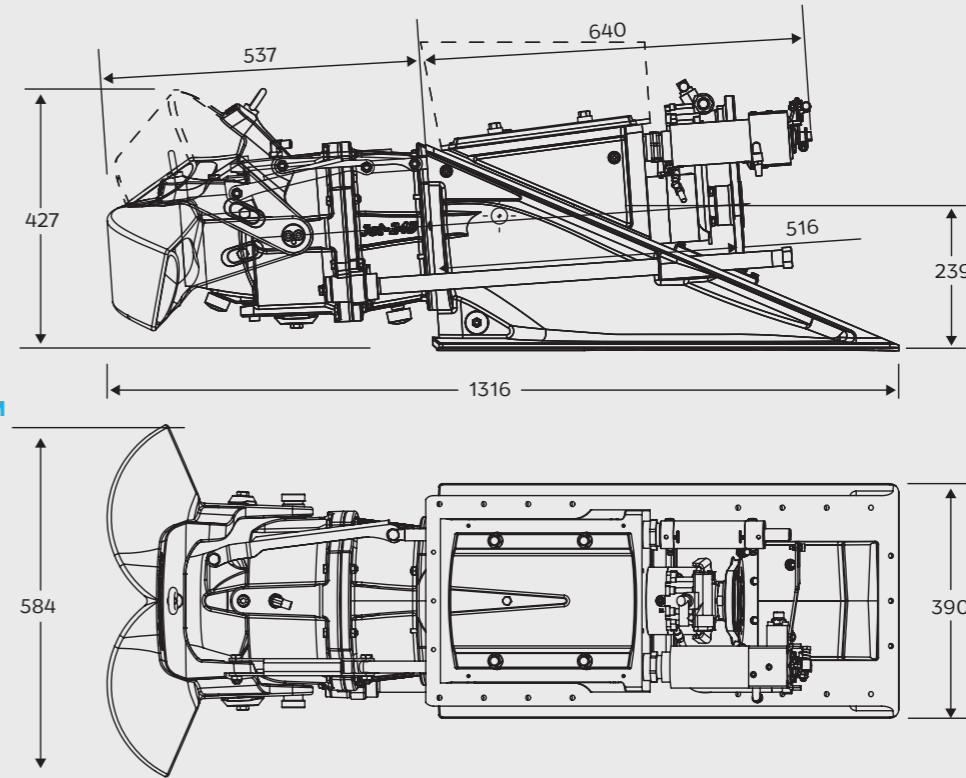

IMPELLER DIAMETER
MAX. 245 MM
(9.6")



MAX INPUT POWER
235 KW
(320 MHP)



JET CONSTRUCTION
ALUMINIUM,
STAINLESS STEEL



REVERSE DEFLECTOR CONTROL
HYDRAULIC OR
SIGMA CONTROLS

AJ 245 POWER/RPM COVERAGE

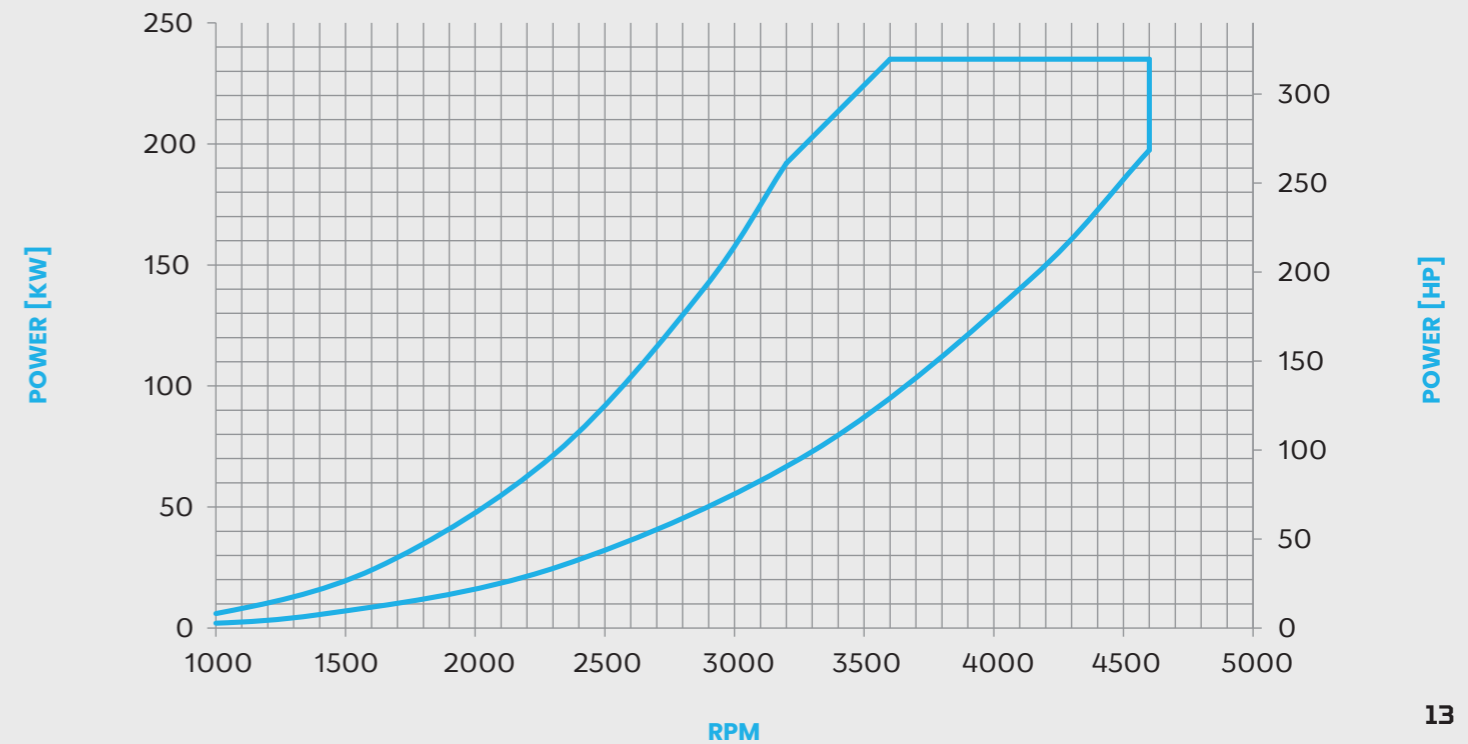

AJ 285

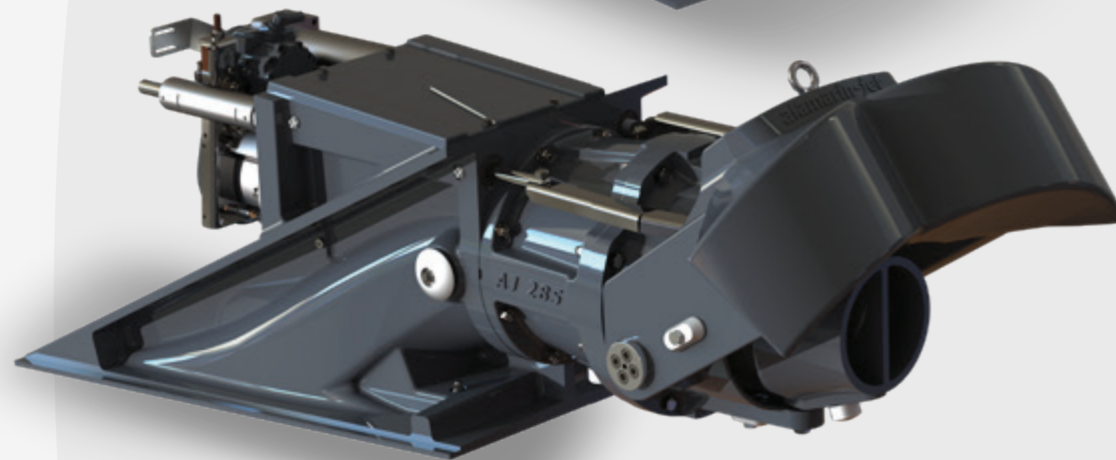
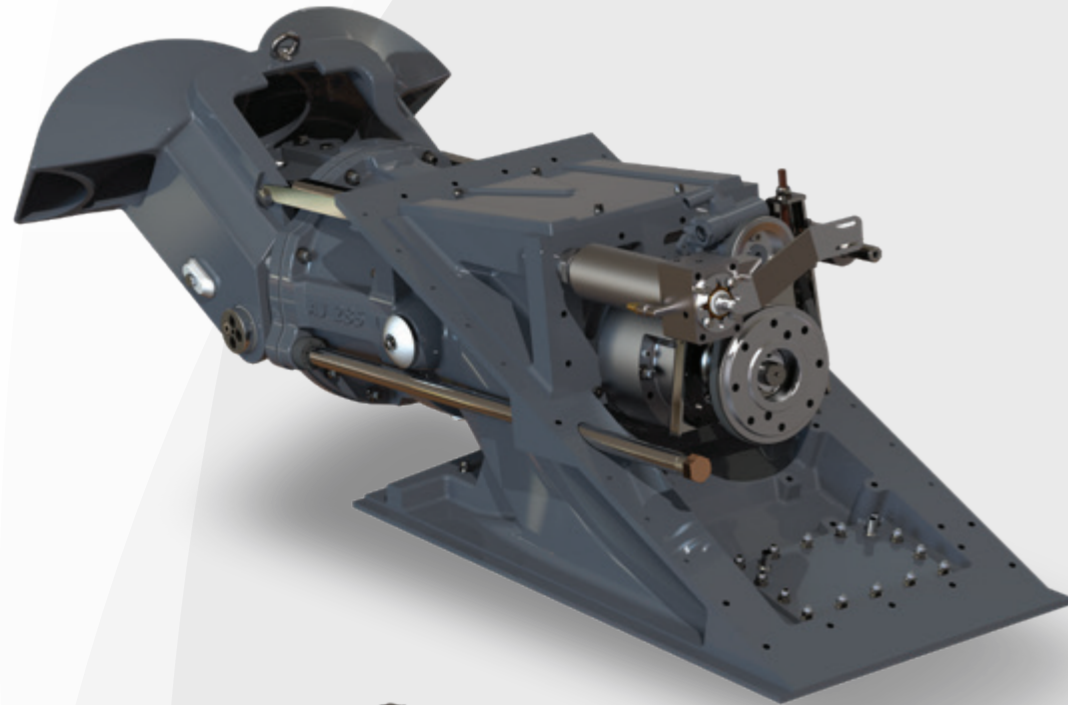

TWO INSTALLATION OPTIONS

PATENTED COMBI-FRAME TECHNOLOGY

Integrated oil cooler and steering cylinder

SPECS



PUMP TYPE
MIXED FLOW,
SINGLE STAGE



IMPELLER SHAFT RPM
MAX. 3700 1/MIN



JET WEIGHT
181 KG
(399 LBS)

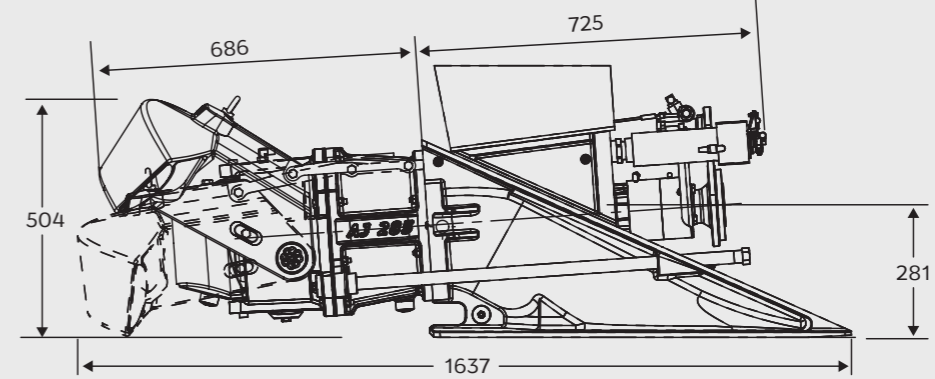

IMPELLER DIAMETER
MAX. 288 MM
(11.3")



MAX INPUT POWER
368 KW
(500 MHP)



JET CONSTRUCTION
ALUMINIUM,
STAINLESS STEEL



REVERSE DEFLECTOR CONTROL
HYDRAULIC OR
SIGMA CONTROLS

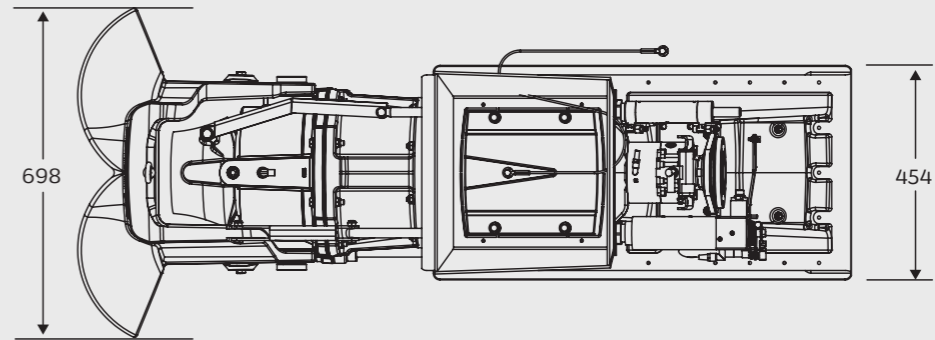

AJ 285 POWER/RPM COVERAGE

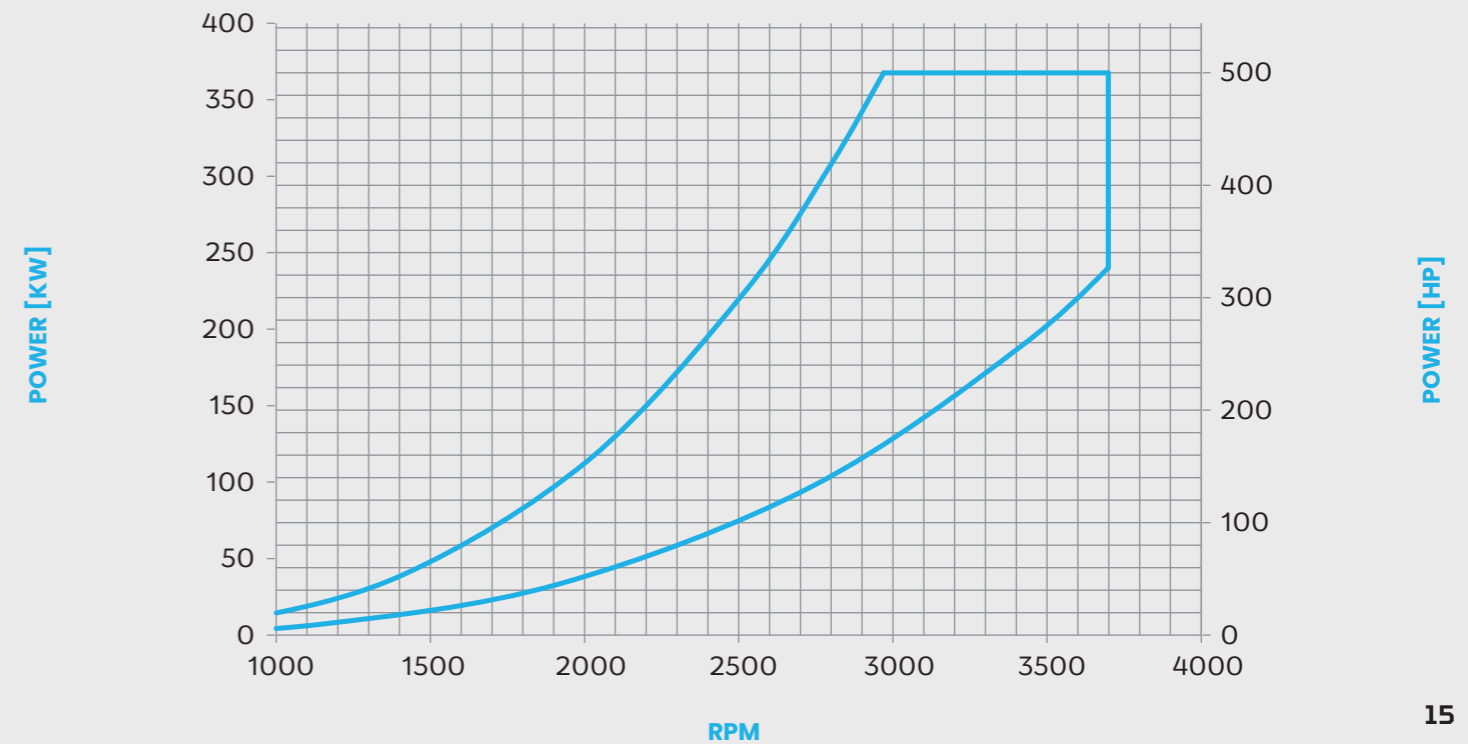

AJ 340

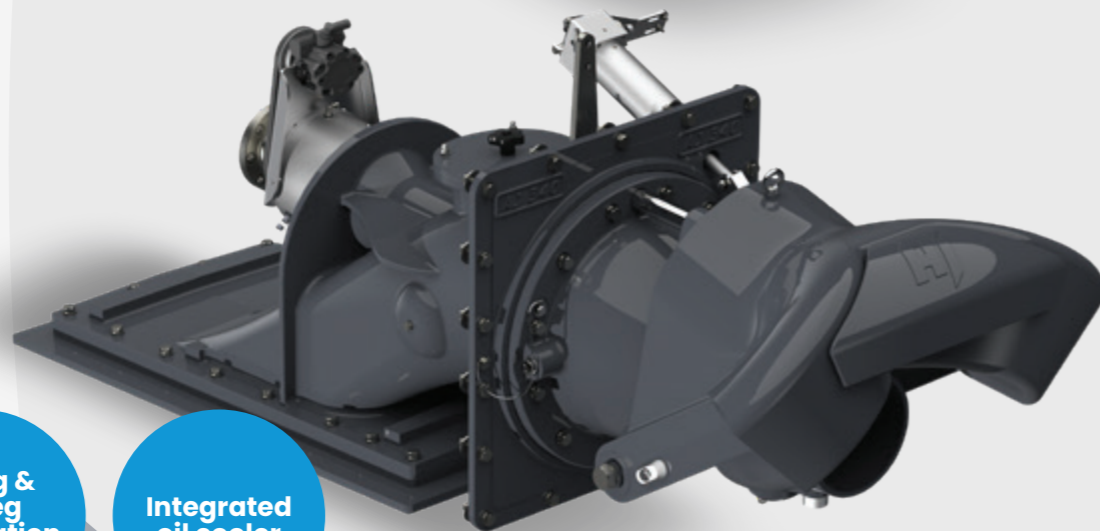
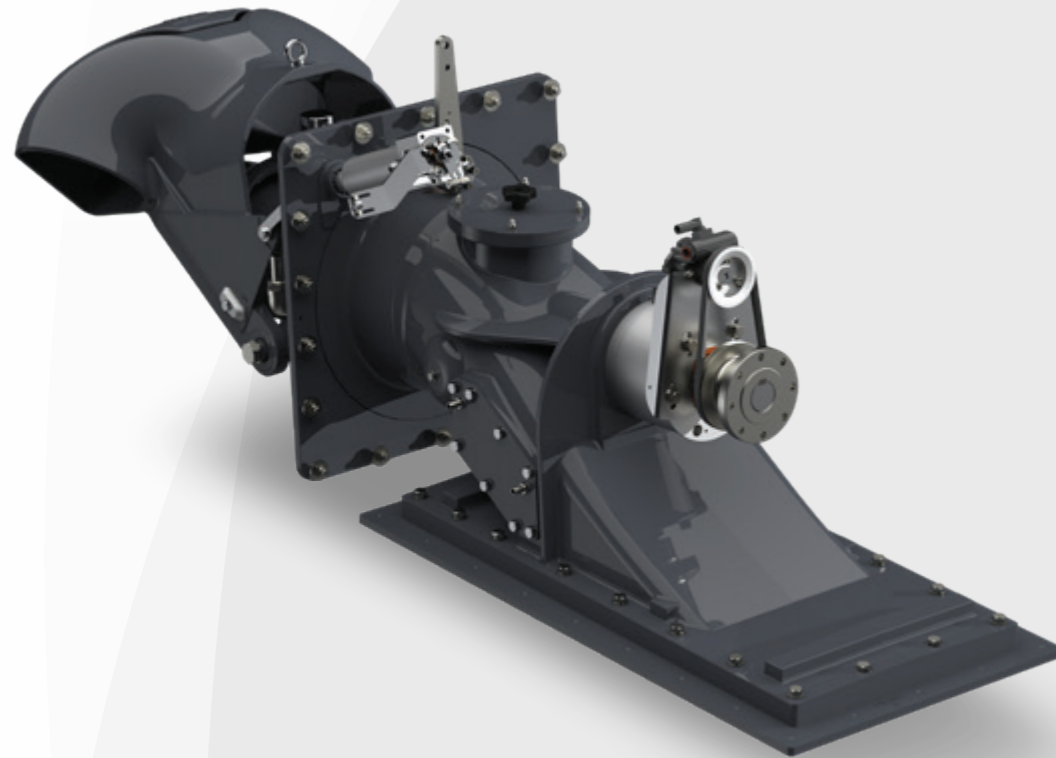

0-deg & 5-deg installation options

Integrated oil cooler

SPECS



PUMP TYPE
MIXED FLOW,
SINGLE STAGE



IMPELLER SHAFT RPM
MAX. 3300 1/MIN



JET WEIGHT
272 KG
(540 LBS)

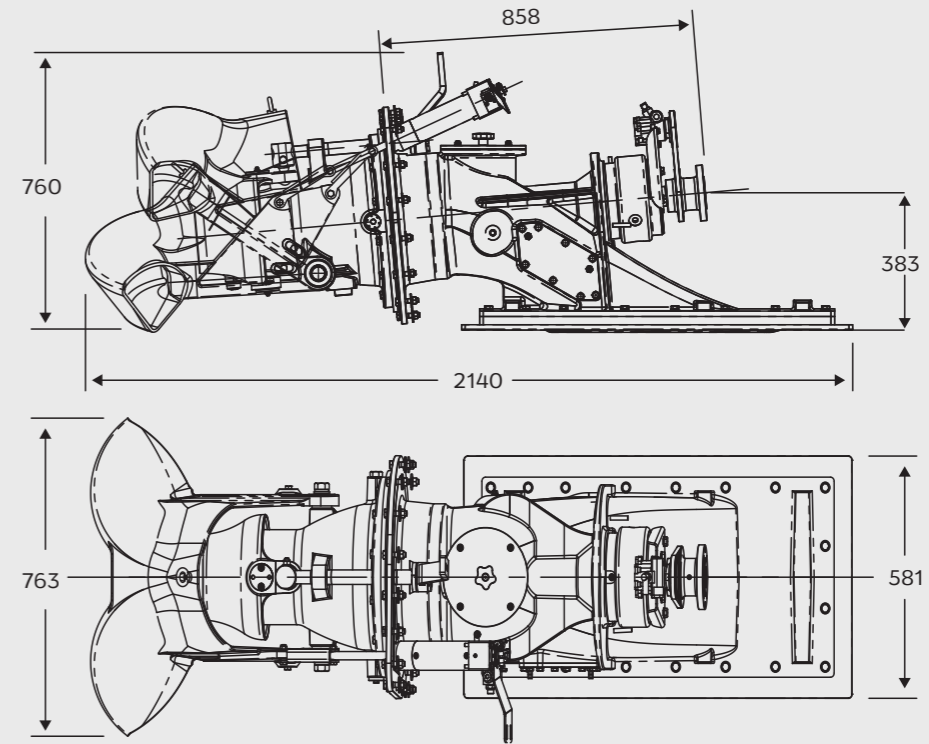

IMPELLER DIAMETER
MAX. 335 MM
(13.2")



MAX INPUT POWER
550 KW
(750 MHP)



JET CONSTRUCTION
ALUMINIUM,
STAINLESS STEEL



REVERSE DEFLECTOR CONTROL
HYDRAULIC OR
SIGMA CONTROLS

AJ 340 POWER/RPM COVERAGE

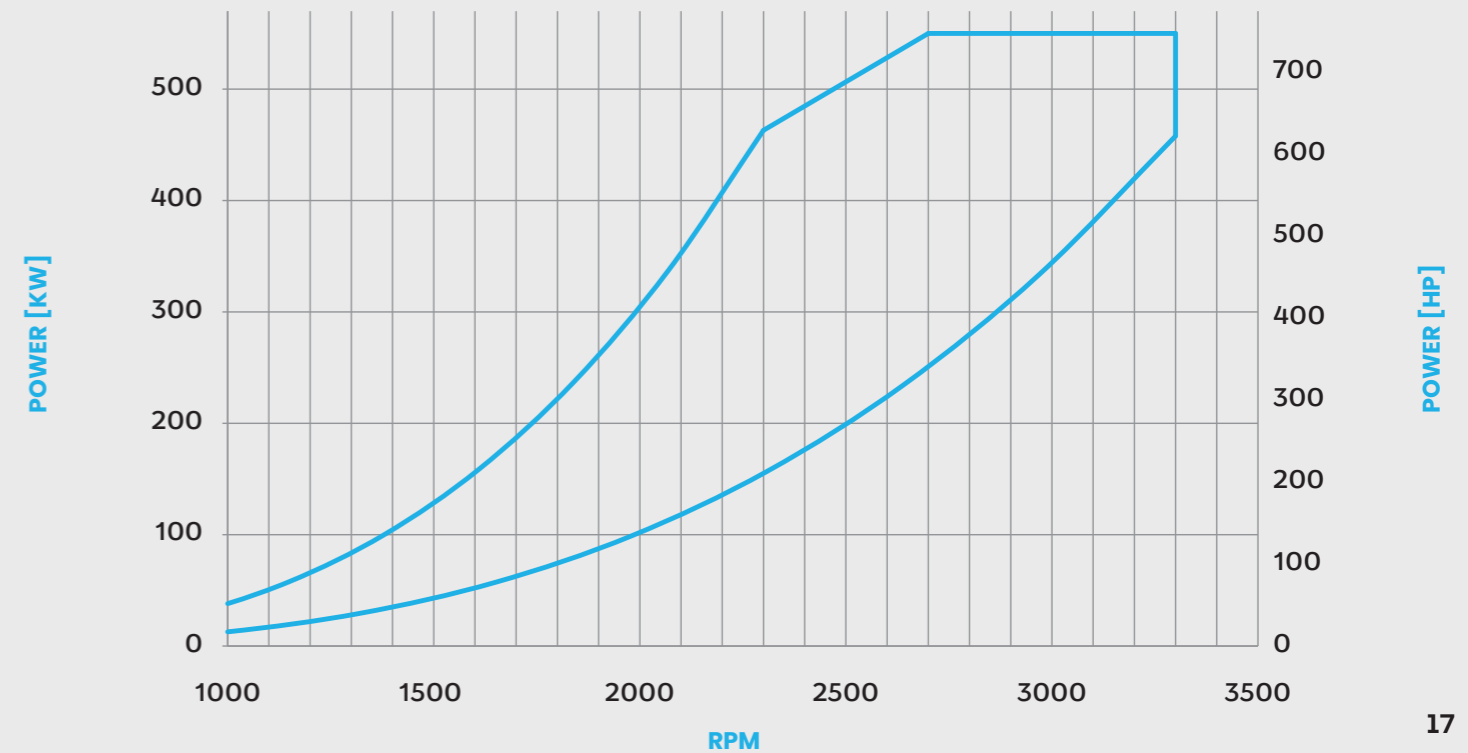

Omega37

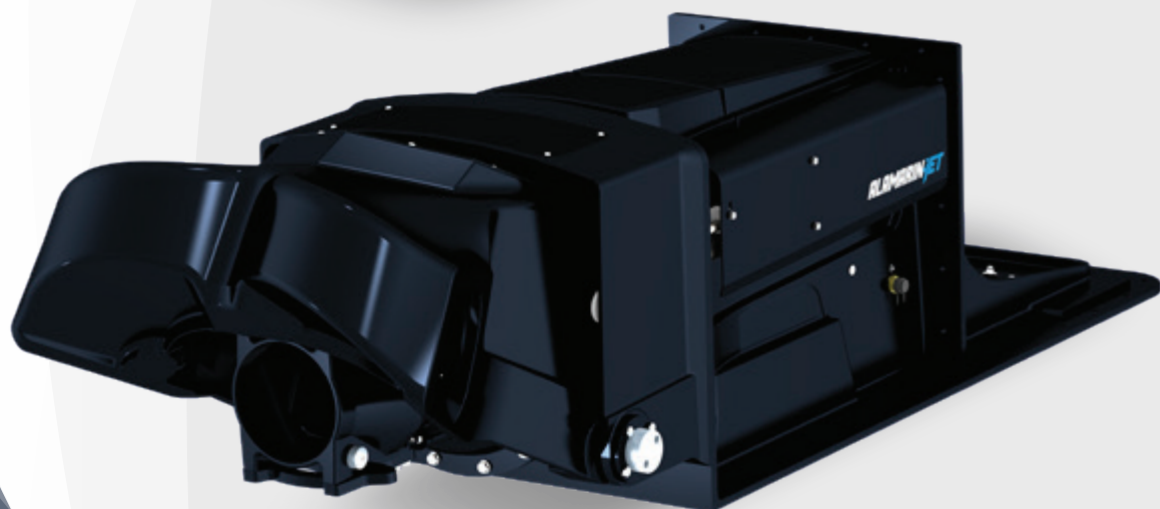

STAINLESS STEEL PUMP UNIT

DAS:
0-deg &
4-deg shaft
options

Integrated
Sigma
Control
System

FIBS:
Frame
Integrated
Bearing
Structure

MIG:
Modular
Intake
Geometry

Structural
bulkhead
adapter

SPECS



PUMP TYPE
MIXED FLOW,
SINGLE STAGE



IMPELLER SHAFT RPM
MAX. 2550 1/MIN



JET WEIGHT
750 KG

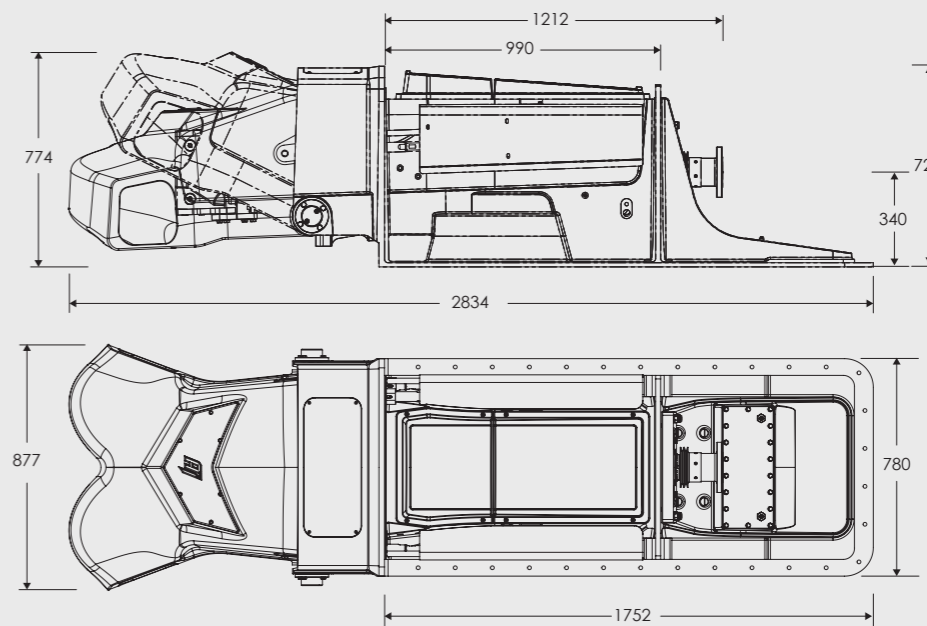

IMPELLER DIAMETER
MAX. 425 MM
(16.7")

MAX INPUT POWER
1000KW
(1360 HP)

JET CONSTRUCTION
ALUMINIUM,
STAINLESS STEEL

REVERSE DEFLECTOR CONTROL
HYDRAULIC OR
SIGMA CONTROLS

OMEGA 37 POWER/RPM COVERAGE

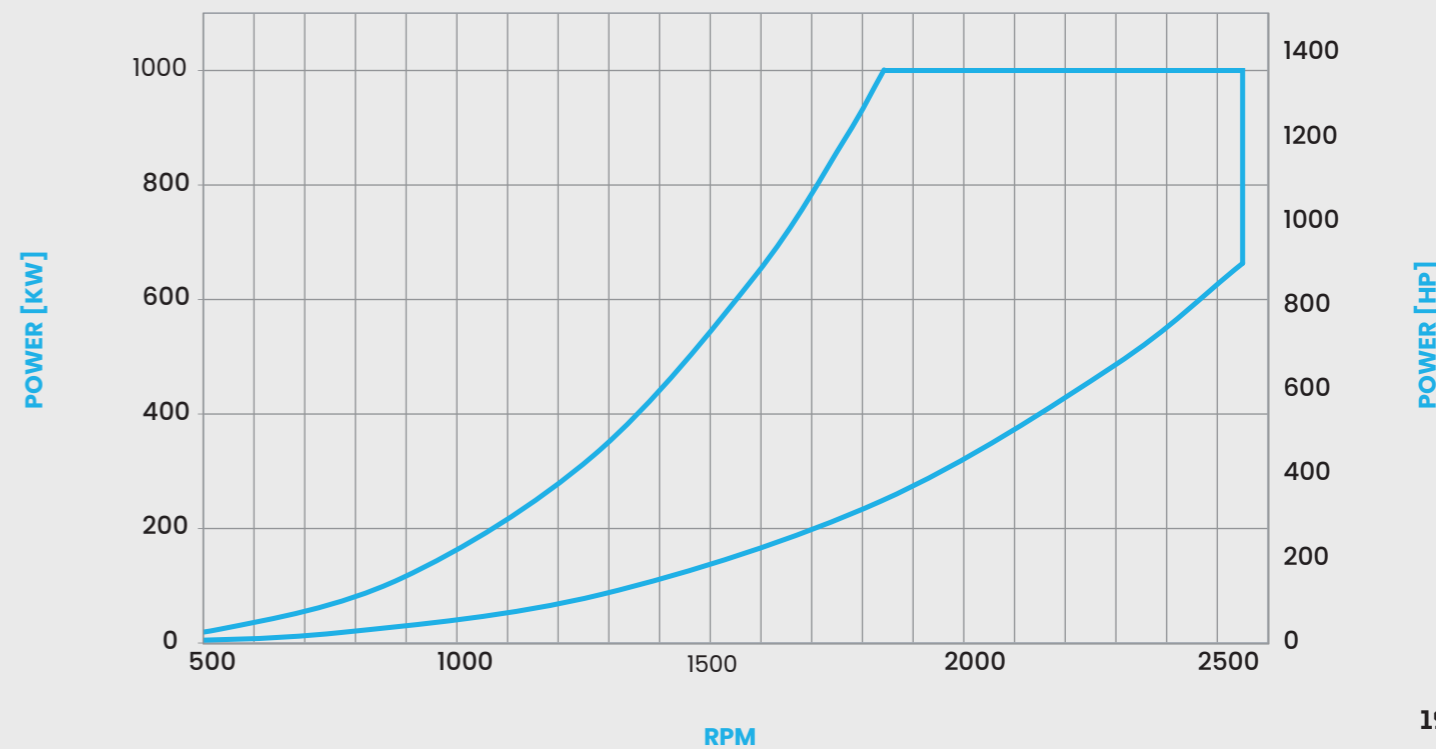

Omega 42



DAS:
0-deg & 4-deg
shaft options

**Integrated
Sigma
Control
System**

FIBS:
Frame
Integrated
Bearing
Structure

MIG:
Modular Intake
Geometry

SPECS



PUMP TYPE
MIXED FLOW,
SINGLE STAGE



IMPELLER SHAFT RPM
MAX. 2300 1/MIN



JET WEIGHT
815 KG
(1796 LBS)

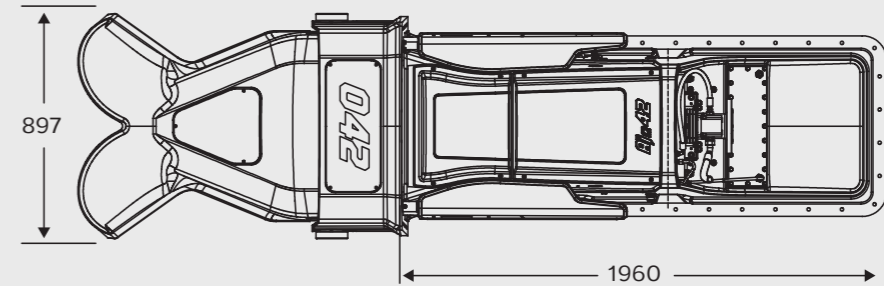
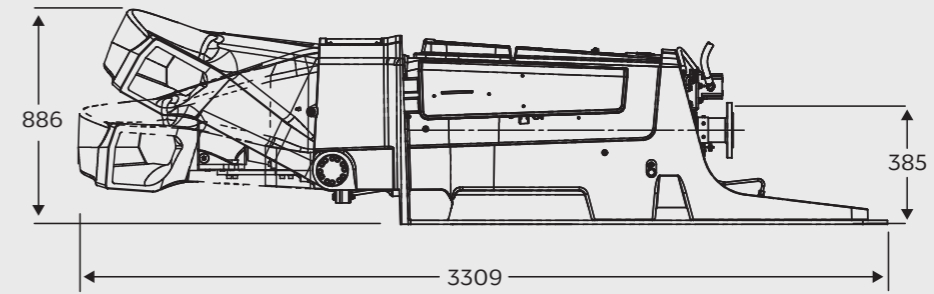

IMPELLER DIAMETER
MAX. 480MM
(18.9")



MAX INPUT POWER
1500 KW
(2040 HP)



JET CONSTRUCTION
ALUMINIUM,
STAINLESS STEEL



**REVERSE DEFLECTOR
CONTROL**
HYDRAULIC OR
SIGMA CONTROLS

OMEGA 42 POWER/RPM COVERAGE

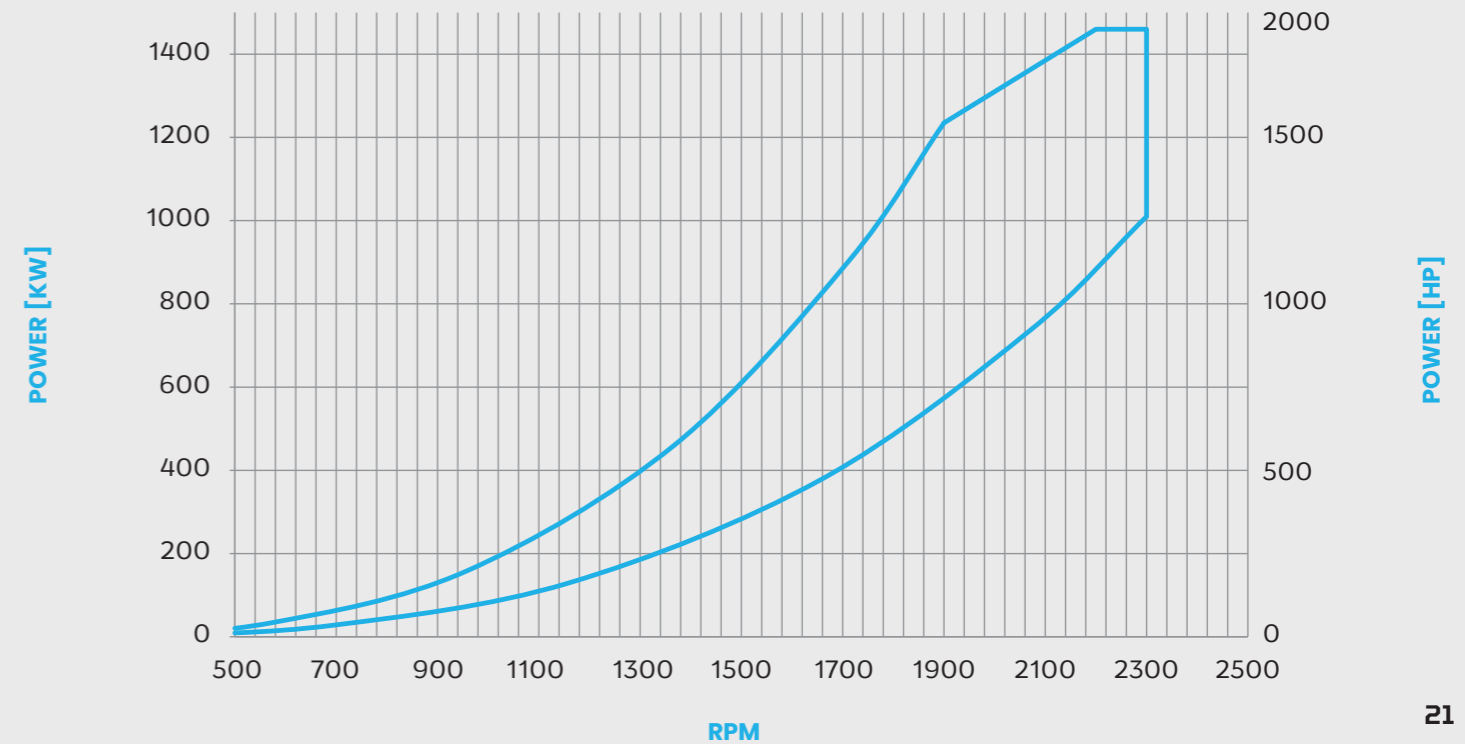

ACU

The Actuator Control Unit system or ACU system is a modular propulsion control system designed to be adaptable for multiple configurations with simple selection of modular components.

The ACU system can be used to control the waterjet deflector and waterjet steering, as well as engine throttle or gearbox engagement.

The main unit in the system is the ACU itself. The ACU is a controller box which can control one (1) actuator at a time within the overall system.

The ACU can accept its own internal potentiometer control, an external signal supply (typically 0-5v) or a CAN signal (NMEA 2000, rudder message).

The ACU can be configured via the integrated button and 'traffic light' LED's or a Service Tool (option).

ACU Service Tool (mobile app)

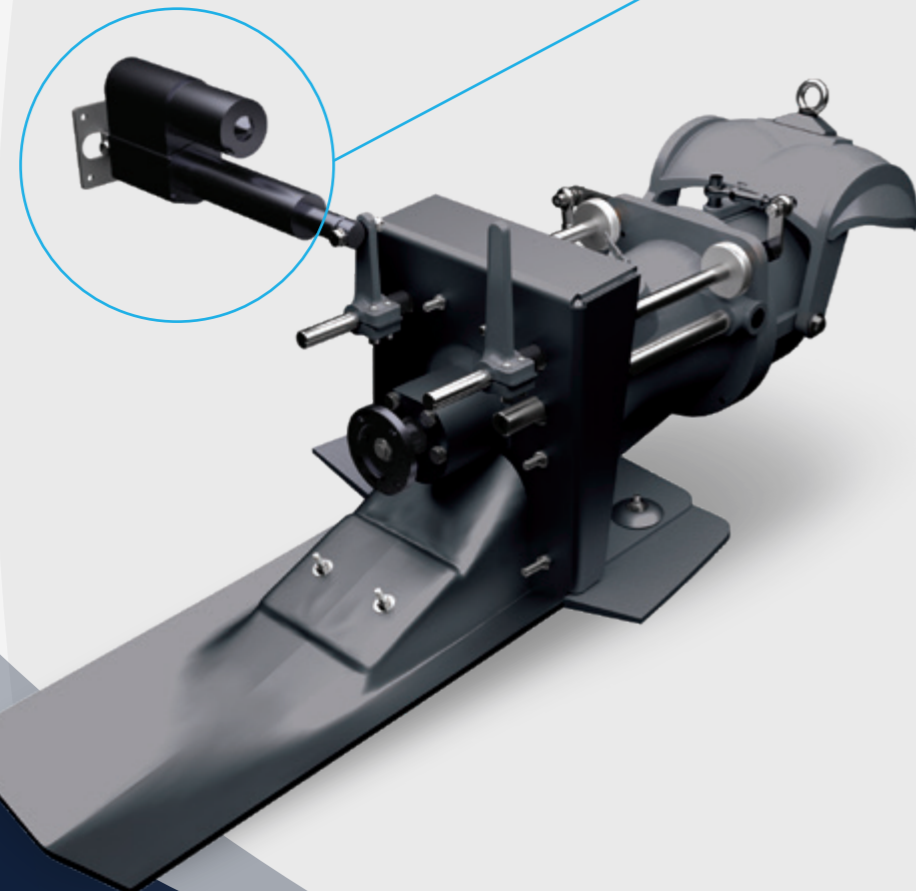
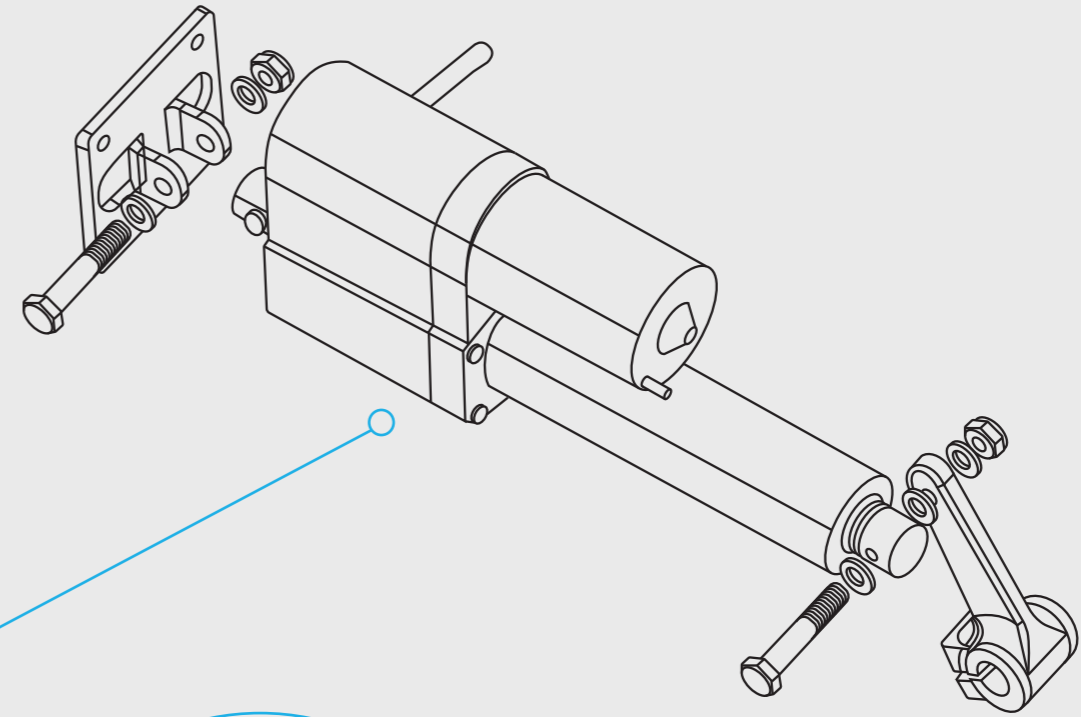
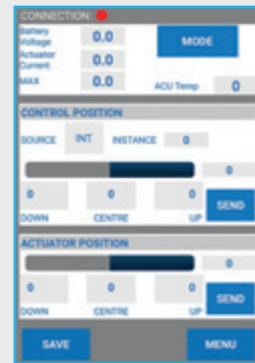

X1

OVDC
+12VDC
Actuator neg
Actuator pos

X2

Pot. 1 GND
Pot. 1 signal
Pot. 1 +5VDC
CAN-L
CAN-H
Alarm
Actuator pot GND
Actuator pot signal
Actuator pot +5V
Pot. 2 GND
Pot. 2 signal
Pot. 2 +5VDC

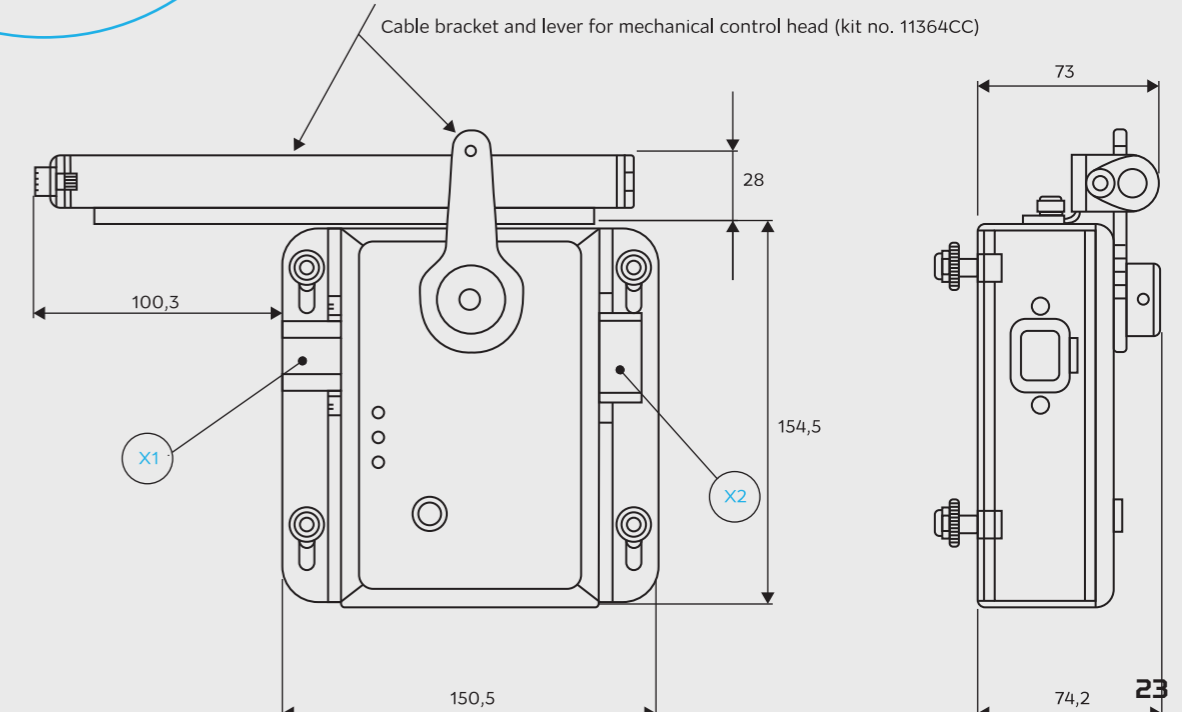

SIGMA

CONTROL SYSTEM

AND INTELLIGENT DYNAMICS

Alamarin-Jet Sigma Control System is an electro-hydraulic integrated drive-by-wire control system. It supports installations from single to quadruple waterjets.

The system is based on modular architecture and the level of features depends on the modules integrated based on the user requirements.

In addition to the standard configuration of Sigma Control System, Intelligent Dynamics is also available as an add-on feature. Intelligent Dynamics has been developed with future markets and industries at its core, such as effortless and straightforward integration with 3rd party autonomous and unmanned systems. Intelligent Dynamics also features highly sophisticated position and heading keeping functions which give significant operational benefits to a wide variety of vessel types and applications.

INTELLIGENT DYNAMICS IS THE GROUP OF FEATURES INCLUDING:

- | Intelligent Position Hold (DPS)
- | Intelligent Vessel Anchor (ANC)
- | Intelligent Heading Keeping (HDG)

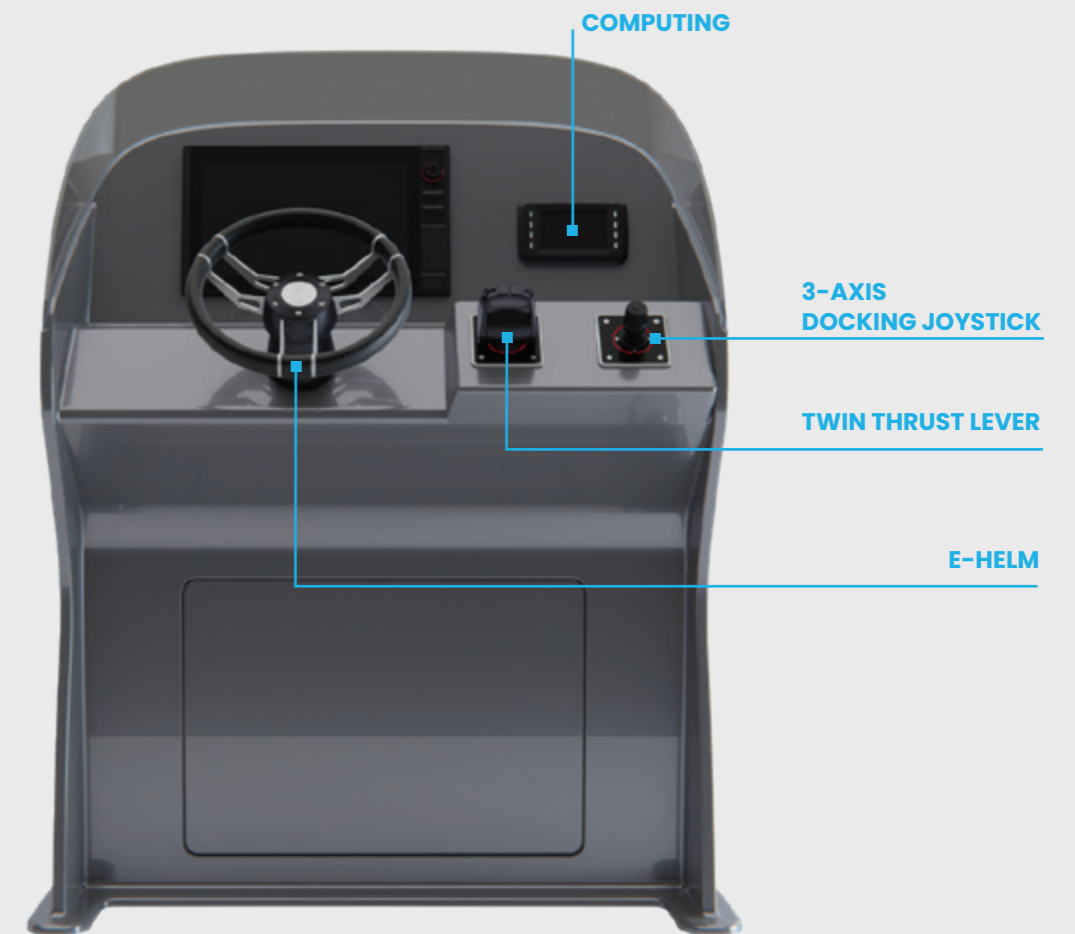

TECHNICAL:

The Sigma Control System is built on a CAN network, the core of the system being the Jet Controller Units (JCU) and Helm Control Units (HCU) being connected via a standardised cable system. Each Jet has its own independent JCU and individual control hydraulics for increased redundancy. Each JCU works also as an individual control network node (CAN Bus). The primary BUS system is capable to carry both, electric power for each JCU node and network communications.

In the case of twin installation and upwards, two electrically separated primary BUS lines are used to increase the redundancy level. All primary control heads are capable to deliver isolated dual output. Each Control Head axis of movement has two electronically separated circuits, making each propulsion line truly separated and independent. Any single point of failure does not affect to another Primary BUS propulsion line.

Modular and scalable architecture – from single installation up to quad installation

Multiple control stations

Multiple control head arrangement options

Flexible BUS architecture – each jet unit acts as an individual BUS

Factory made modular cabling system, no custom-made cables required

Easy to approach design

Installation is based on plug'n'play modules

Intuitive walk through commissioning procedure

Simple to use, new High Resolution Display with modern UI/UX usability

Digital engine interface – direct digital CAN-CAN Throttle control

Sophisticated diagnostics – multiple data logging and diagnostics

Intelligent self-monitoring system. Temperature, Pressure and Fluid

USV Ready – comprehensive low-level (CAN) and high-level (IP) interfaces

Delta DP

PRECISE DP CONTROL FOR THRUSTERS AND RUDDERS

Delta DP is a modular high-level propulsion control system that integrates vessel's propulsion, steering and navigation systems. It provides three main controlling modes: Manual control, Dynamic Positioning mode and Autopilot mode. DP capabilities include dynamic positioning, virtual anchor, and 3-axis joystick propulsion force control. In addition to DP features, Delta DP includes automatic heading keeping, track keeping and has an external waypoint autopilot interface capable of interfacing with NMEA2000 or NMEA0183 autopilot computer.

SYSTEM ARCHITECTURE

- ✓ Modular CAN bus connected system
- ✓ Proprietary J1939 inspired CAN network
- ✓ NMEA2000 interface for GPS and external autopilot
- ✓ 5" Computing Display Unit
- ✓ Robust real-time control module for each thruster

CONTROL HEAD OPTIONS

- ✓ Twin-levers option
- ✓ 3-axis joystick
- ✓ E-Helm

RUDDER CONTROL OPTIONS

- ✓ "Bang bang" control
- ✓ PWM control for proportional valves

BOW THRUSTER CONTROL OPTIONS

- ✓ Analog signal
- ✓ PWM controlled proportional valves

INTELLIGENT FEATURES

- ✓ 3-axis joystick force control
- ✓ Dynamic positioning
- ✓ Virtual anchor
- ✓ Heading autopilot
- ✓ COG autopilot
- ✓ Track following autopilot

DRIVELINE CONTROL OPTIONS

- ✓ Optoisolated analog engine control
- ✓ J1939 CAN engine control
- ✓ Gearbox solenoid control
- ✓ ZF ClearCommand DP-interface option

Vessel types:



For Thrusters and Rudders

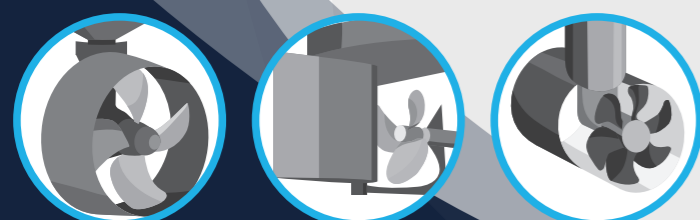

Delta DP - System Diagram

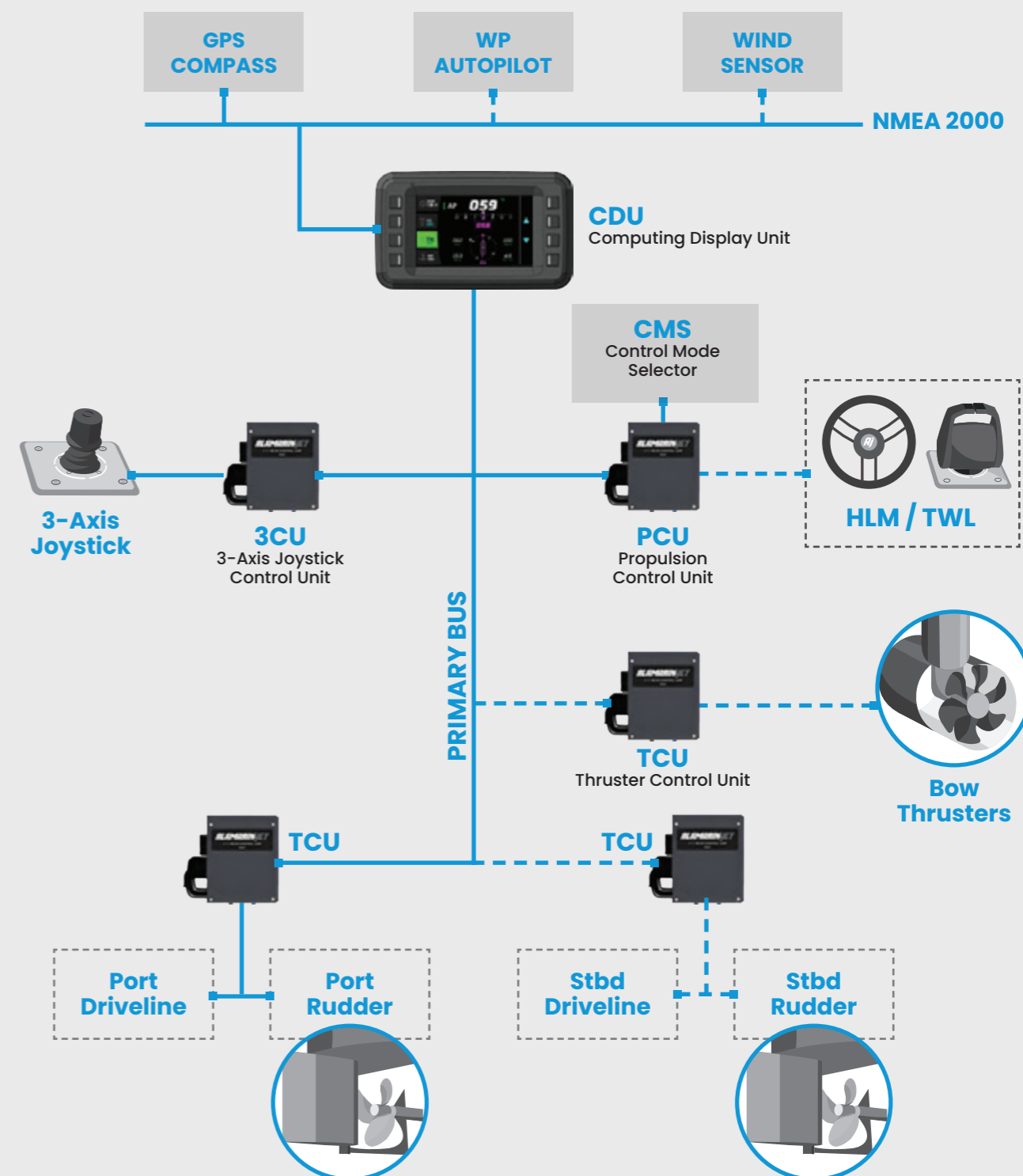



Alamarin-Jet Oy
Tuomisentie 16, FI-62300 Härmä, Finland

www.alamarinjet.com