

THE INFORMATION CONTAINED HEREIN IS CONFIDENTIAL AND PROPRIETARY TO ALAMARIN-JET OY AND IS NOT TO BE REPRODUCED, MODIFIED OR USED WITHOUT PRIOR PERMISSION OF ALAMARIN-JET OY OR ITS DULY AUTHORIZED REPRESENTATIVE. ALL RIGHTS RESERVED.

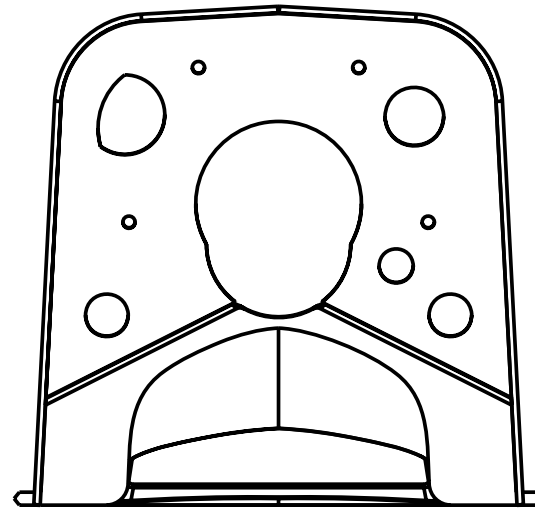
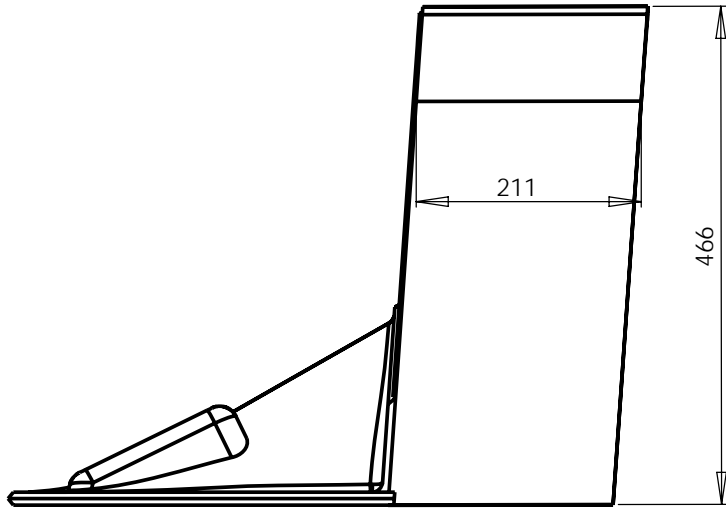
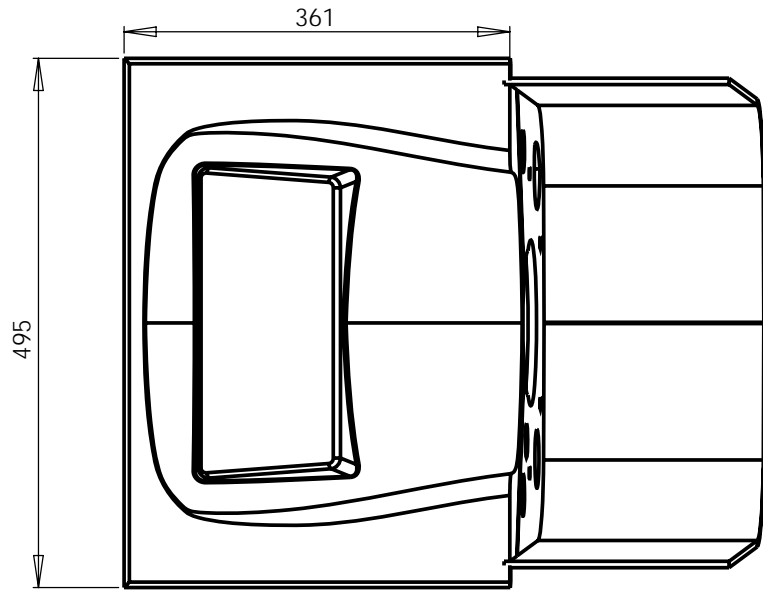

A					
Tunnus Badge	Muutoksen ja korjauksen selitys Amendment and correction explanation			Pvm. Date	Hyväksytty Approved

Työtapaohjeiset toleranssit: Iästava työvä SFS4011 (ISO2768) keskisarja, hitsatut rakenteet SFS3393 pituusmitat ja kulmat luokka E, muoto ja sijaintitoleranssit DIN8570BL3 luokka E, valukappaleet SFS-ISO8062	Pintakäs. menetelmä - Surf. treatm.	Pinta-ala - Surf. area [m ²]	Paino - Weight [kg]	Suun. Design.	HRa	20.1.2009
	Säily - Colour	1.25	14.04	HRa	30.10.2008	
	Asennusosa 288		Tuotekoodi	Ver. - Rev.		
			10437	A		
		Koko Size	Mitta kaava Scale	Sivu Sheet		
		A3	1:4	3/3		